

# Preferred Pack<sup>®</sup>

## CARTON SEALERS

*The New Industry Standard for Quality and Reliability*

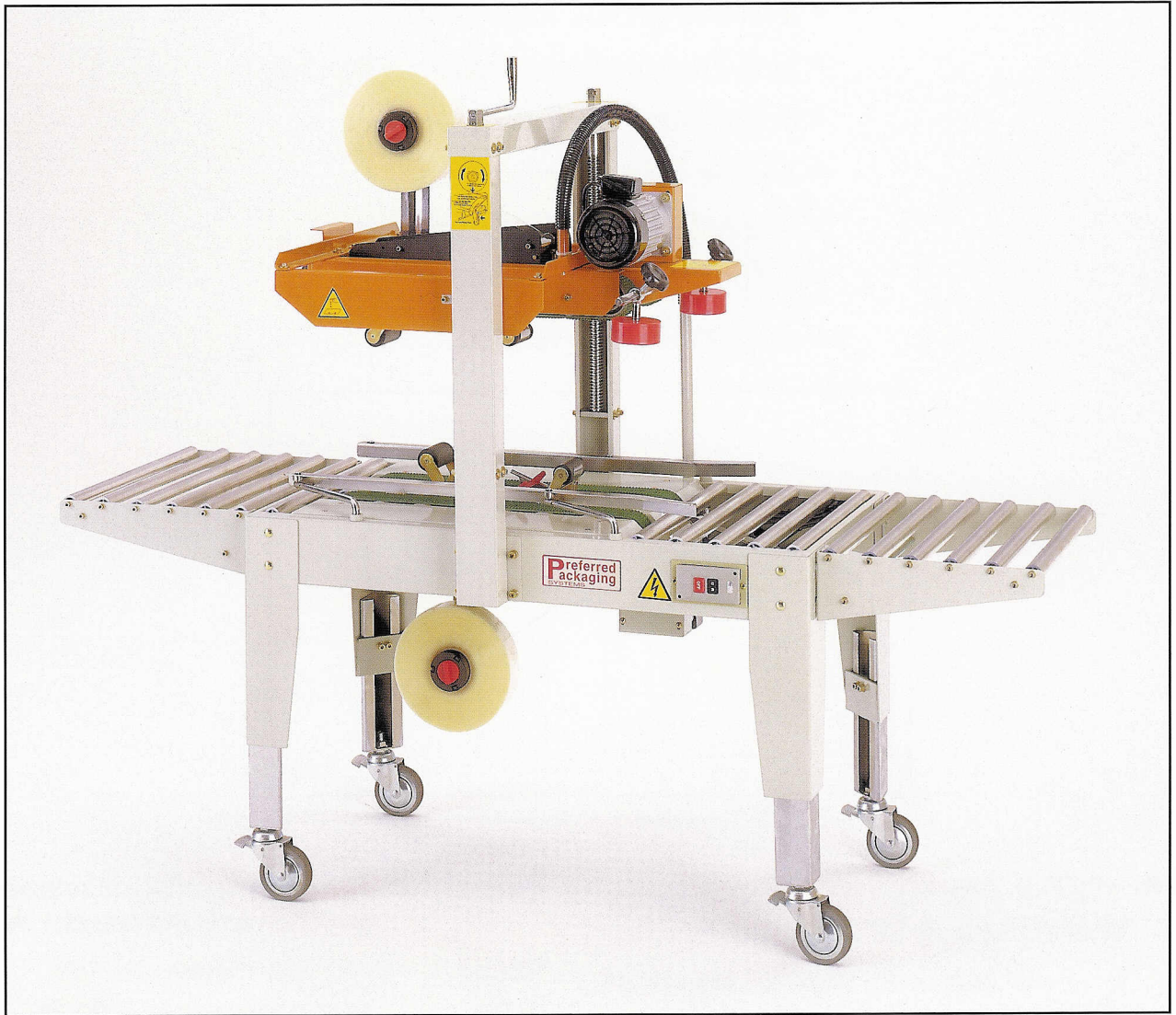

### **\*Model PP-703**

Semi-Automatic Uniform Carton Sealer with Easy Manual Carton Size Adjustment. Top and Bottom - 4 Drive Belt Design. Featuring the New Universal Tape Head that will Run 2" or 3" Tape with No Changeover Required.

\* Shown with Optional Infeed and Discharge Roller

The operator simply folds the top flaps of the corrugated carton and feeds it into the machine. The PP-703 applies a single tape strip to both the top and bottom of the case simultaneously. This 4 belt drive (two top belts and two bottom drive belts) is a heavy duty versatile machine designed for dependable performance and easy operation. The PP-703 can be easily adjusted in only seconds to process a different size carton.

## **STANDARD FEATURES**

- Unique Universal Tape Head  
Will Run 2" or 3" Tape
- Interchangeable Tape Heads
- Side Pressure Rollers to Close Box Top
- Bottom Tape Air Blower
- 4 Drive Belts - Positive Feed
- Heavy Duty Locking Casters
- Fully Adjustable Bed Height
- Adjustable Tape Tension

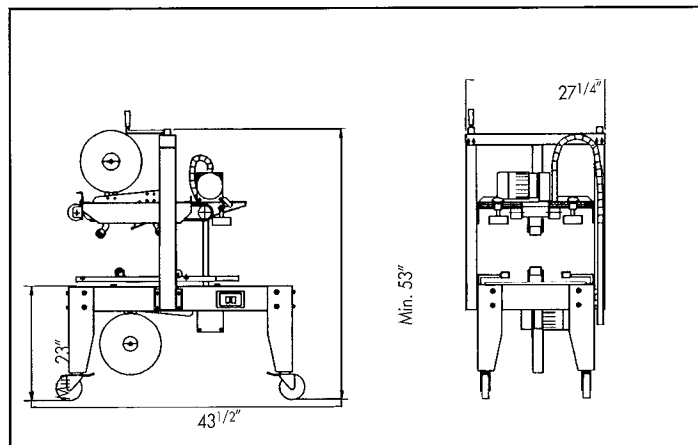

## **SPECIFICATIONS:**

**Carton Size:** Length: 6" Min. to Infinite

Width: 7" Min. to 20" Max. (Std. Tape Head)

6" Min. to 20" Max. (2" Tape Head)

Height: 4" Min. to 20" Max.

**Machine Speed:** 75 Ft/Min - production rate depends on carton size and operator dexterity

**Electrical:** 110 Volt, 1 Phase, 10 AMP

**Weight:** NW: 260 lbs., Gross: 325 lbs.

**Machine Size:** 43" L X 27" W X 52 1/2" H

\* Model PP-703WS available for wider, and taller boxes up to 36" x 36"

**AUTHORIZED DISTRIBUTOR**